

IR INFRARED INDUSTRIES



IR2200 Oxygen Analyzer

TABLE OF CONTENTS

SECTION	TITLE	PAGE
1	<u>INTRODUCTION</u>	1
	1.1 General Description	1
	1.2 Specifications	1
2	<u>UNPACKING AND VISUAL INSPECTION</u>	4
	2.1 Unpacking Instructions	4
	2.2 Reporting Damage	4
3	<u>INSTALLATION</u>	6
	3.1 General	6
	3.2 Precautions	6
	3.3 Mechanical	6
	3.4 Electrical	7
	3.5 Gas Handling System	9
	3.6 Connection of Gas Lines	9
4	<u>OPERATION & CALIBRATION</u>	13
	4.1 Description of Controls	13
	4.2 Operation of Analyzer	14
	4.3 Adjustment of Alarm Set points	16
5	<u>MAINTENANCE</u>	19
	5.1 Sensor Cell Replacement	19
	5.2 Trouble Shooting Guide	21
	5.3 Recommended Spare Parts	22
6	<u>PRINCIPLE OF OPERATION</u>	23
7	<u>APPENDIX</u>	25
	7.1 Plastic Fitting Installation Instructions	25
8	<u>WARRANTY</u>	26

SECTION 1

INTRODUCTION

1.1 GENERAL DESCRIPTION

The Infrared Industries analyzer Model IR-2200 is an electrochemical oxygen analyzer which offers superior performance by continuously monitoring the concentration of oxygen gas in a sample stream. The analyzer is designed utilizing a disposable sensor cell with a guaranteed 6 month life for ambient oxygen level measurements. This life is extended for lower levels of oxygen. Acid gases can have a detrimental effect on cell life.

The analyzer offers a three range digital display of oxygen concentration. A recorder output voltage is provided with the standard instrument. Optional equipment includes 4-20mA current output, dual set point alarms, and an on-board sample pump, and corrosion resistant flow regulator.

Features include low cost, easily replaced sensor cell, built-in pressure regulator, ambient air calibration, and simple field servicing.

1.2 SPECIFICATIONS

Gas Sample Quality

Temp (gas sample)	32° to 158°F
Temp (ambient)	40° to 105°F
Input Pressure	1 to 10 psig - standard limits
Flow Rate	0.3 to 3.0 scfh (Factory set at 1 scfh)
Moisture	0-100% (avoid condensation)

Performance

Accuracy	±2% fs is at 72°F - all ranges
Response Time	30 sec. for 90% response, 10 sec. typical for small step change
Stability	±2% fs over 30 days typical

1.2 SPECIFICATIONS (continued)

Electrical

Power Input	100/120/220/240 Vac 50/60 Hz- standard
Output Signal	0 to 100 mV range - standard. Also available 0 to 10 mV, 0 to 1V, 0 to 5V
Visual	3½ digital display

Gas Flow System

Gas Connection	Stainless Steel, Polypropylene, Polyethylene ¼" tubing fittings
Cell Life	6 month min., for ambient O ₂ levels, longer for lower O ₂ concentrations
Shelf Life	6 months storage, off load, refrigerated in air-tight package.

Standard Ranges

Percent Analyzers 0 to 1/10/25%

Dimensions (Figure 1)

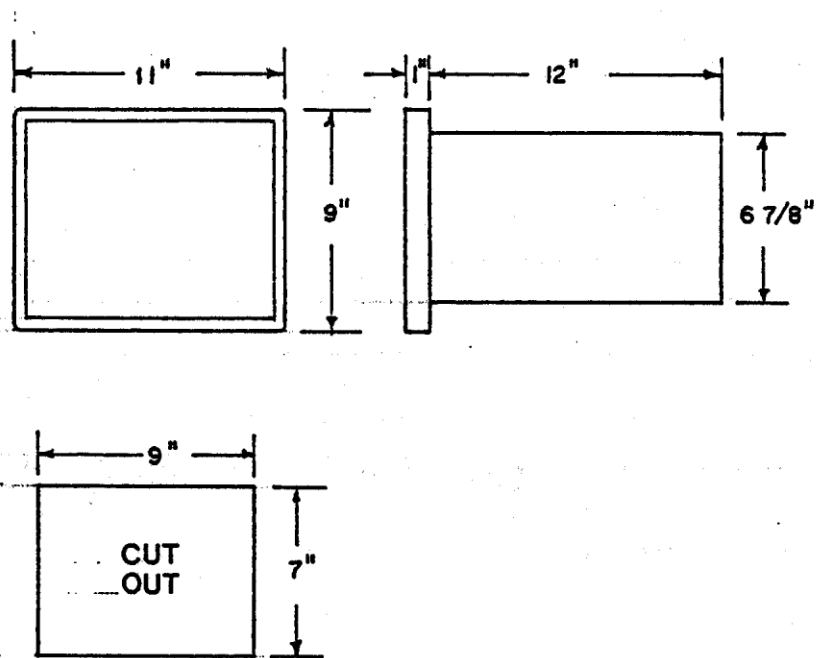

Figure 1: IR-2200 Outline Dimensions

SECTION 2

UNPACKING AND VISUAL INSPECTION

2.1 UNPACKING INSTRUCTIONS

Inspect the shipping container for any signs of damage or shock. Open the shipping container and remove the instrument and protective packing. Inspect the instrument front panel, rear panel, and enclosure for any signs of damage.

Turn instrument on its side and remove the two #8 sheet metal screws used to retain the drawer during shipping. Save the shipping container, screws and all protective foam pieces to be used in the event the unit has to be shipped in the future. Turn the instrument upright.

Open the IR-2200 by loosening the two captive retainer screws on the front panel (Figure 2). Pull the drawer out to provide access to the inside. Inspect the inside plumbing and electronics for any signs of loose connections or damage. Insure that the main PC Board just behind the front panel is firmly seated in the connectors on the drawer assembly. Close the drawer assembly. Tighten the front panel retainer screws finger tight.

2.2 REPORTING DAMAGE

Should any damage have occurred due to shipping and handling, notify both the shipper and Infrared Industries. If there is any visual damage to the shipping container or packing materials, it is important to save these for inspection by the shipper.

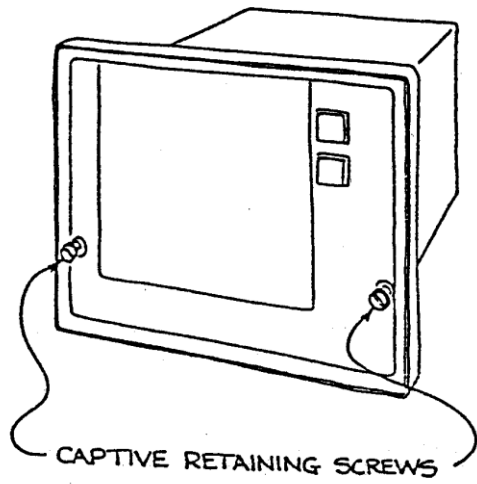

CAPTIVE RETAINING SCREWS

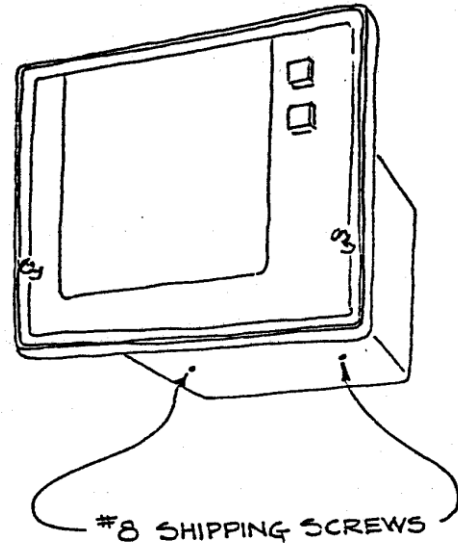

#8 SHIPPING SCREWS

Figure 2: Unpacking Illustration

SECTION 3

INSTALLATION

3.1 GENERAL

The compact size and roll-out tray construction of the Infrared Industries Model IR-2200 allow for ease of maintenance and service. The instructions below are for a typical installation. The particular application may require special handling and sample conditioning. If you have any doubts or questions regarding your application, consult with our Tech Support at (800) 344-0321.

3.2 PRECAUTIONS

To insure accurate operation of the instrument, the following precautions must be taken. The area in which the instrument will be located should be free from excessive dust or humidity and should not be subject to direct sunlight or radiant heat. Rapid ambient temperature fluctuations should be avoided. Environmental temperatures should be maintained between 40° - 105°F (5° - 40°C). Provide a shield if any radiant heat source is present near the instrument. The IR-2200 is not designed to be intrinsically safe and must be installed in a non-hazardous area or factory installed in a suitable enclosure. For recommendations on explosion-proof or other protective enclosures, contact the factory.

Do not install the instrument near electrical equipment which causes power source disturbances (radio-frequency furnaces, electrical welders, etc.), and do not connect the instrument's power line to the same power source used by such equipment. Be sure that the power source matches the voltage rating specified before connecting the instrument. See Section 3.4 on Electrical Connections.

3.3 MECHANICAL

The minimum depth behind the front panel should not be less than 15 inches to allow for external wiring, plumbing, and the air flow required for cooling.

3.4 ELECTRICAL

AC power is supplied via a three-prong electrical cord. A female connector is supplied to plug into the AC input/voltage selection module located on the rear panel. To determine if the correct AC voltage has been selected, refer to Figure 3. For 100 or 120 Vac operation, a 3/8 Amp fuse should be used. For 220 or 240 Vac operation, a 1/4 Amp fuse is required. Do not connect to AC power until after referring to Section 3.6 Preliminary Check-out.

To connect a recorder to the analyzer, install the positive input to the "RCDR+" terminal and the negative input to the "RCDR-" terminal.

A range indication output, labeled "RANGE IND" is provided on the rear panel. An approximately $\pm 5V$ level is measurable between the common terminal and the selected range terminal (HI, MID, or LOW); the terminals corresponding to other ranges will indicate approximately 0V (zero) with respect to the common terminal. Each range terminal is capable of driving one TTL load. Excessive loading of these terminals may cause improper operation of the range switch.

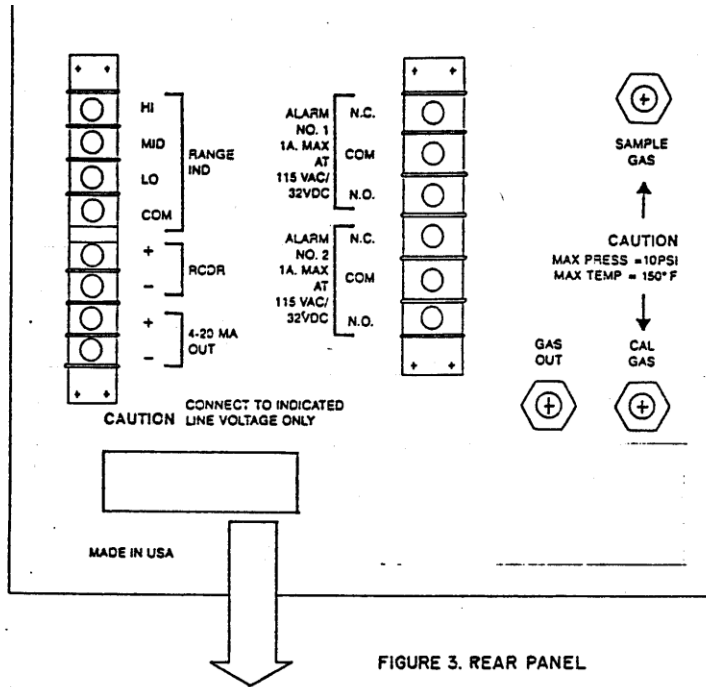

FIGURE 3. REAR PANEL

VOLTAGE SELECTION

Operating voltage is shown in Connector window.

HOW TO SELECT OPERATING VOLTAGE

1. Open cover door and rotate fuse-pull to left.
2. Select operating voltage by orienting PC Board to position desired voltage on top left side. Push board firmly into module slot.
3. Rotate fuse-pull back into normal position and re-insert fuse into holders, using caution to select correct fuse value.

Figure 3: Rear Panel

OPTIONAL OUTPUTS

Optional 4-20mA current output and adjustable dual set point alarms are available. The current output circuit is designed to provide a 4-20mA into a maximum loop resistance of 1000 Ω . The output terminals are located on the rear panel.

NOTE

On special orders the current transmitter may be provided with either 1-5mA or 0-20mA. This is a factory setting.

The alarms provide relay closures that can be monitored. The two alarms HI or LOW limit alarms. They are located on the rear panel and labeled "ALARM NO. 1" and "ALARM NO. 2". The contacts are rated at 1 Amp, 32Vdc or 115AC. See the Operations Section for information on setting the alarm points.

3.5 GAS HANDLING SYSTEM

The minimum requirement for the gas handling system is to have a means of transporting the sample to the analyzer and a source of calibration gas for checking the calibration. Regulators should be used for all gas sources and they should be set for 1 to 10 psig. The exhaust line should be kept free of unnecessary sharp bends and other restrictions to minimize backpressure in the sensor cell. Use 1/4" tubing of a material compatible with the sample gas stream. Keep the interconnecting tubing between the analyzer and the calibration gas as short as possible to minimize the time required for purging the system. Avoid using rubber or soft vinyl tubing, as incorrect readings may result due to absorption. Use inline filters and driers as necessary to eliminate particulates from the sample and reduce the moisture content so that condensation will not occur within the analyzer. The fittings at the rear of the analyzer are of the 1/4" compression type. Installation instructions are given in the Appendix for this type of fitting.

The "CHECK" function allows input of a calibration gas through the rear panel "CAL GAS" input. Uncontaminated ambient air can be used to set the high range to 20.9% oxygen. See the Calibration Section for more details.

3.6 CONNECTION OF GAS LINES

Figure 5 shows the standard flow system for the analyzer unit. The schematic also shows the location for an optional inboard diaphragm pump.

A. Procedure for Standard Analyzer Models

Analyzers that do not contain optional equipment in the inlet flow system can be

connected to the sample gas line after verifying that the inlet pressure does not exceed the maximum level of 10.0 psig. All gas connector fittings on the analyzer are 1/4" plastic compression type fitting. It is recommended that the gas stream to be analyzed be connected to the unit using 1/4" tubing.

Good engineering practice dictates that a minimum of surface area exists on the internal surfaces of the gas lines connecting the point of sample extraction and the analyzer. Also, the lines must be capable of withstanding the 10 psig, maximum, at which the gas sample is to be delivered to the analyzer.

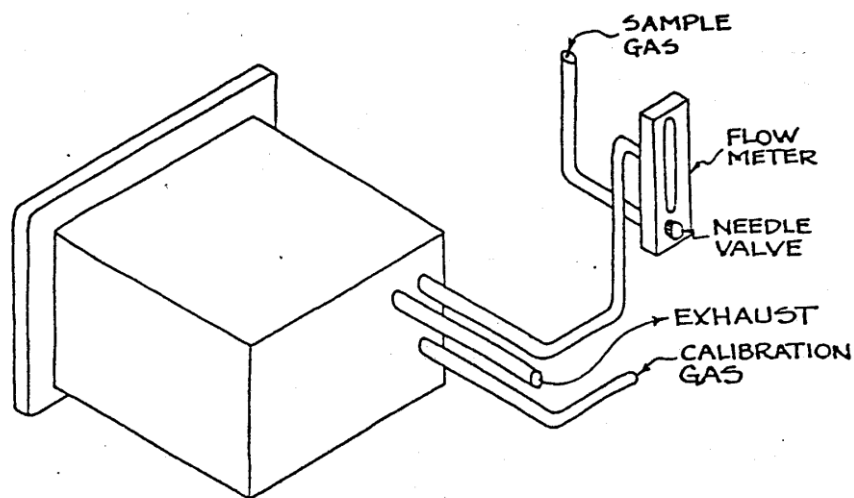

Figure 4: Typical Gas Handling System

3.6 CONNECTION OF GAS LINES (continued)

B. Calibration Gas Inlet

For calibration convenience, an additional gas inlet has been provided. In the event that gas certification testing or the like is required when operating the analyzer, a gas standard can be connected to this auxiliary inlet. By activating the "CHECK" switch, the standard gas can be directed to the sensor cell. Activation of the "CHECK" switch places the analyzer in the HI Range regardless of the range switch position.

C. Gas Outlet Line

The gas sample leaving the analyzer will be virtually the same in composition as the incoming stream. Thus, in situations where sample availability is restricted, the sample can be returned to the main stream if desired (so long as at least 1 psig pressure differential can be maintained between the inlet and outlet of the analyzer).

The flow regulator built into the analyzer is factory set to provide a uniform flow of 1 scfh with inlet pressures of 1 to 10 psig. This setting is not to be changed. A steady state flow is recommended; changing or fluctuating flow rates may result in temporarily exaggerated indications by the instrument.

IMPORTANT

Avoid flow restricting devices on the outlet since pressure build-up in the cell will result in abnormally high readings.

Each range potentiometer has been factory set to establish the proper signal response from the cell to the meter. The range potentiometers are mounted on the printed circuit board. In the field the only gain adjustment required is the overall gain via the "CAL" control.

A calibration gas with a known concentration of oxygen, balance nitrogen, should be utilized. The oxygen concentration should be as close to the expected sample concentration as conveniently practical.

Ambient air can be utilized as a calibration gas for the high range. *Note: Ambient air is always 20.946% O₂ up to 15 miles above sea level.*

With a calibration gas flowing through the analyzer, allow the reading to stabilize. Adjust the "CAL" potentiometer for agreement between the analyzer reading and known calibration gas concentration. When using ambient air, adjust for a reading of 20.9%.

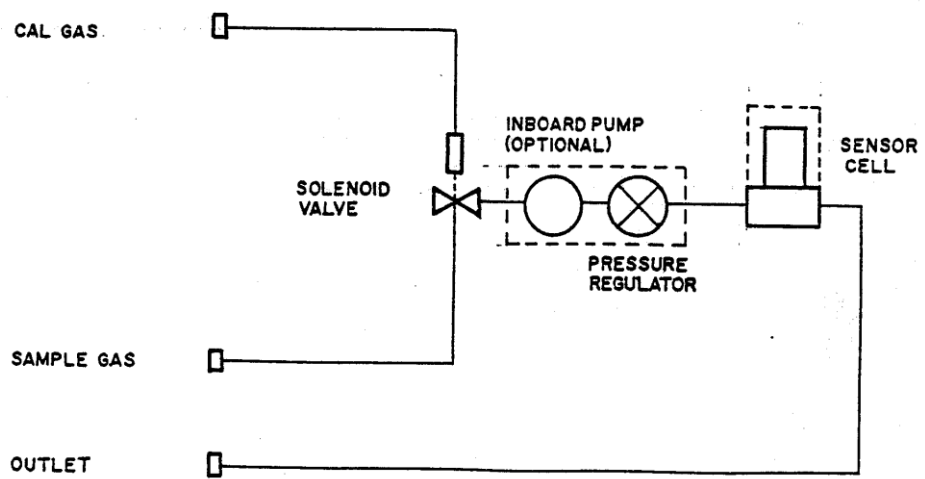

Figure 5: Flow Diagram

SECTION 4

OPERATION & CALIBRATION

4.1 DESCRIPTION OF CONTROLS

A. "ON-OFF" Switch

The "ON-OFF" switch controls the application of AC power to the instrument. It starts the pump (when supplied) which creates a flow of approximately 1 scfh. The switch is illuminated when the power is "ON".

B. "CHECK" Switch

The "CHECK" switch actuates the solenoid valve which transfers the flow from "SAMPLE IN" to "CALIBRATION IN". It also places the instrument in "HI" range, regardless of the range switch position.

C. "RANGE" Switch

The "RANGE" switch sets the measurement indication range of the instrument. The "HI" range is 0-25%, the "MID" range 0-10%, and the "LO" range 0-1%.

D. "CAL" Control

The gain of the instrument is controlled by the "CAL" potentiometer on the front panel. The analyzer has factory set gain adjusting potentiometers for the "LO" and "MID" ranges (R105 for "LO", R106 for "MID" range) on the main PCB.

This adjustment should be made periodically, at least once every 30 days. It is accomplished by flowing a known standard of O₂ through the analyzer. After stabilization of the reading, adjust the "CAL" potentiometer for agreement of the meter reading and the known concentration of O₂ in the standard. Ambient air can be used as a source of 20.985% oxygen.

4.1 **DESCRIPTION OF CONTROLS** (continued)

E. "ZERO" Control

The analyzer is equipped with a "ZERO" adjustment potentiometer. This is located on the front panel. It has been factory set and should not require any field adjustments. If a check on zero is desired, it is recommended that a very pure sample gas (i.e. research grade nitrogen) be allowed to equilibrate with the unit. This may require several minutes. With the IR-2200 in low range and a steady minimum reading achieved, corrections using the "ZERO" control can be made at this point, if required.

4.2 **OPERATION OF ANALYZER**

Operation of the analyzer is easy and its performance reliable and accurate if attention is paid to a few cautions.

The power cord must be connected to a safety-grounded source of 50/60Hz AC power at a voltage which is the same as that shown on the selector plate in the power receptacle on the rear panel of the analyzer.

- Sufficient time must be allowed when introducing gas into the analyzer, to fully purge the apparatus connecting the gas source and the sensor of all residual gas; sufficient time must also be allowed to "scrub" the interior surfaces of the connecting apparatus to remove all residual oxygen which may have been absorbed from gases previously flowing in the system (including from ambient air if the system has been left open to the atmosphere.
- The "wetted" surface area of the apparatus connecting the gas source and the fittings on the rear panel of the analyzer must be minimized; they must also be made of smooth materials with low oxygen permeability.
- The sample/calibration gas pressure at the inlet of the analyzer must be between 1 and 10 psig. Both the sample calibration gases must enter the analyzer at approximately the same pressure.
- The analyzer outlet lines must not restrict the flow of expended sample gas in any manner.

4.2 OPERATION OF ANALYZER (continued)

- The "RANGE" switch must be set to "HI" prior to applying power to the instrument and be switched to lower ranges only when the indicated concentration falls within the limits of the lower range.

NOTE

The display will be blank (no digits will be displayed) when the gas concentration exceeds approximately 110% of the full-scale of the selected range. This may occur when the analyzer is first switched "ON", especially if the gas lines have been open to the atmosphere. As the lines are purged, the display will first unblank and then gradually indicate lower concentrations until the correct reading is displayed.

ADDENDUM FOR IR-2200 GAS ANALYZERS WITH SPECIAL AUTO-RANGING FEATURE

The IR-2200 with auto-ranging utilizes one of its circuits, normally used for an alarm output, to automatically switch ranges displayed on the digital panel meter, when the display reaches 19.00.

This allows for a higher resolution display of oxygen values below that value, without sacrificing the ability of use ambient oxygen (20.9%) for calibrating the instrument.

When the instrument changes the range displayed on the panel meter, the recorder output is not changed. This maintains continuity in process measurements close to 19% oxygen.

Because the circuitry utilizes one of the alarms, only one set of DPDT alarm contacts is available to the user, but these outputs are standard with the auto-range feature.

The standard recorder output is 0-100 Mv for 25% oxygen. Other special outputs are available to allow convenient recorder outputs for almost any concentration of oxygen. For example, a 250 Mv recorder output for 25% oxygen would yield a 100 Mv recorder output for 10.00% oxygen.

4.3 ADJUSTMENT OF ALARM SETPOINTS

Adjustable set point alarms are available as options. When supplied they provide a HI (#2) and LOW (#1) level alarm. Each alarm has a trip point which can be set at any point within the range of the analyzer. Form C relay contacts are brought to the rear panel for interface to external equipment. These are labeled "LIMIT NO. 1" for the low level alarm, and "LIMIT NO. 2" for the high level alarm.

The rear panel relay contact designators (NC, NO, COM) refer to the relay in the relaxed state. When the set point of the alarm has been exceeded the relay will be energized. This will give continuity between the "NO" and "COM" terminals; no continuity between the "NC" and "COM" terminals.

Potentiometers on the main PCB are provided for adjusting the alarm trip points. See Figure 7 for their location. LED's below the potentiometers aid the operator in the adjustment. They illuminate when the trip point is exceeded. It is mandatory the trip points be adjusted on the range which is to be utilized during the measurement! The set point is as a percentage of full scale and, thus, will represent a different concentration on each range. To adjust the set points of the alarms, the analyzer must be "ON" and reading forced to the desired trip point by adjusting the "CAL" control on the front panel. The set point is established by adjusting the appropriate PCB potentiometer until the LED just turns on, indicating activation of the alarm. Following adjustment of the set points, recalibrate the analyzer using a known concentration of oxygen and adjustment of the "CAL" control.

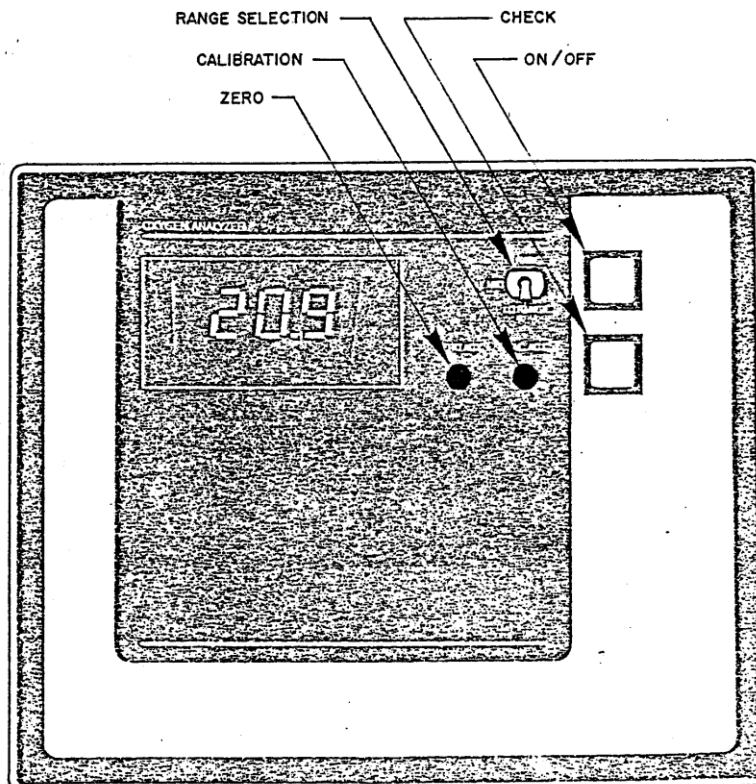

Figure 6: IR-2200 Front Panel

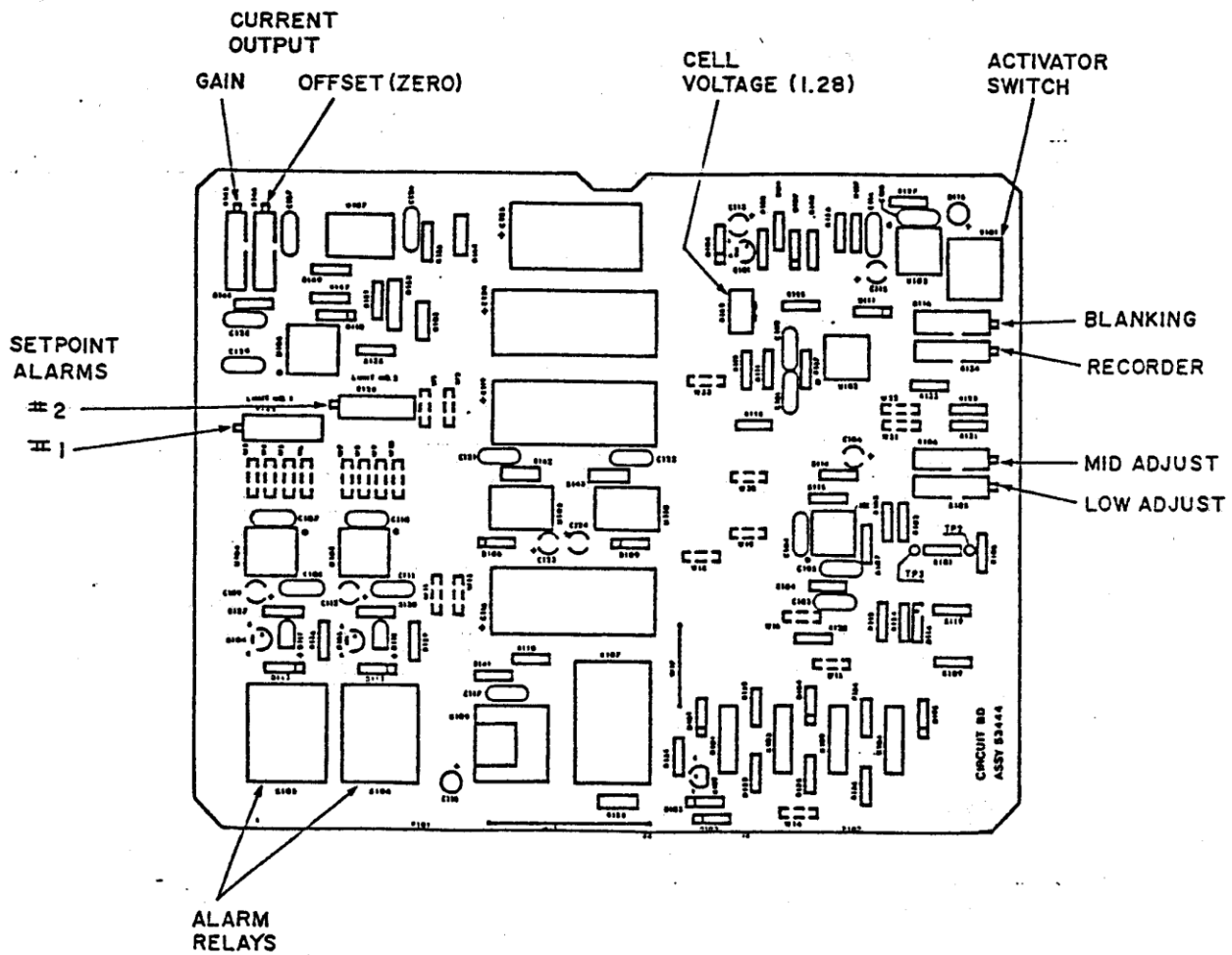

Figure 7: Main PCB

SECTION 5

MAINTENANCE

5.1 SENSOR CELL REPLACEMENT

The only expected routine maintenance is the occasional replacement of the O₂ cell. This is easily accomplished by the following procedures:

1. Loosen the two front panel retainer screws and slide the drawer assembly all the way forward.
2. Remove the electrical plug from the top of the cell assembly (see Figure 8).
3. With a Phillips #2 screwdriver, remove the two screws which hold the top and bottom of the cell holder together.
4. Lift off the cell holder top.
5. Slide the old O₂ sensor cell out of the holder.
6. Making sure the "O" ring is in position; place the new O₂ sensor cell in position.
7. Replace the cell holder top and the two screws.
8. Connect the electrical plug.
9. Slide the drawer assembly back in the enclosure and fasten the front panel retainer screws.

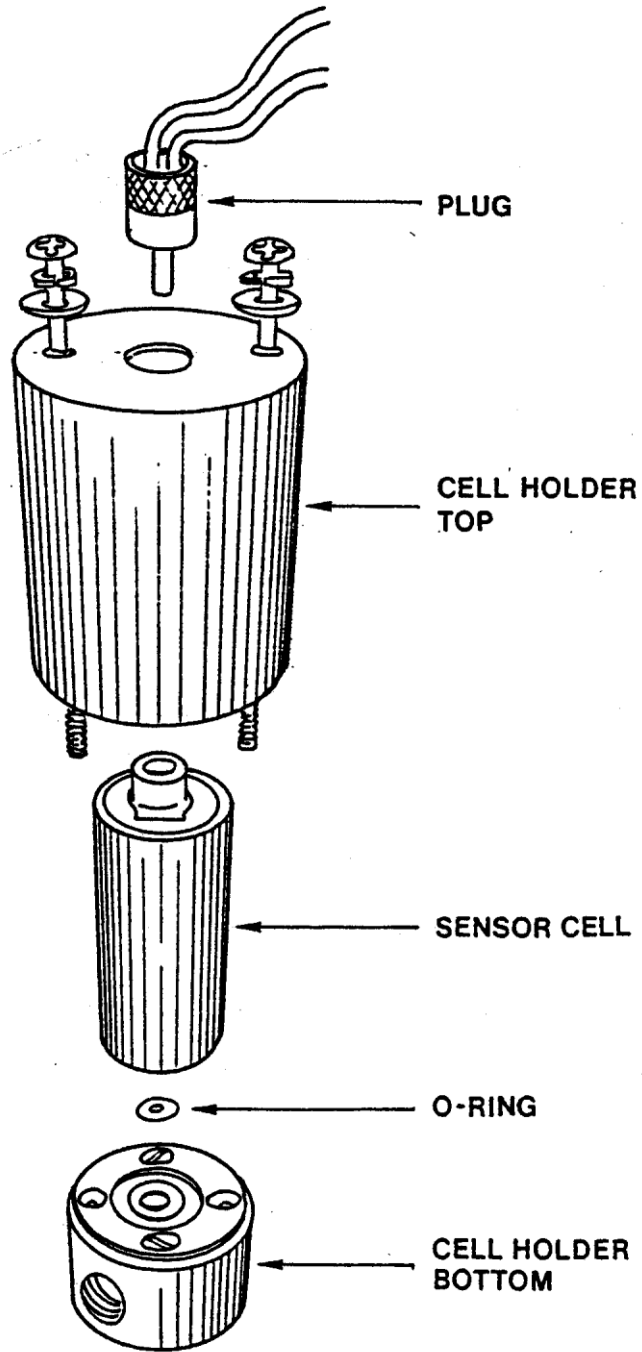

Figure 8: O₂ Sensor Cell & Holder

5.2 TROUBLE SHOOTING GUIDE

NOTE: This guide has been prepared for use by qualified instrument technicians; and servicing of any internal component, which could represent a significant hazard due to the possibility of electrical shock, should be referred to personnel who are thoroughly familiar with the equipment.

<u>SYMPTOM</u>	<u>CORRECTIVE ACTION</u>
Continuously increasing O ₂ readings	1. Leaking gas connections; ambient air being drawn into sample system. Check system for leaks and eliminate them.
Continuously decreasing O ₂ readings	2. No sample flow - supply adequate flow. 3. Cell life exceeded - replace sensor cell.
Insufficient "CAL" control	1. Cell life exceeded - replace sensor cell.
No meter display No "ON/OFF" switch illumination	1. Check for AC power to instrument. 2. Circuit breaker tripped - reset. 3. Faulty "ON/OFF" switch - replace if necessary.
Fluctuating readings	1. Flow rate is fluctuating - adjust internal regulator via rear panel adjustment to obtain steady flow (consult Applications Engineer for instructions). 2. Power supply out of regulation - replace main PCB.

5.3 RECOMMENDED SPARE PARTS

<u>PART #</u>	<u>DESCRIPTION</u>
56251	Main PCB (no options)
56254	Main PCB (4-20mA option)
56252	Main PCB (alarms option)
56253	Main PCB (4-20mA + alarms option)
56261	Sensor Cell Assy
261-210	ON/OFF or check switch
262-130	Digital panel meter
53440	Pump Assy (optional)
53511	Solenoid Assy
273-791	1/4" Plastic fittings, bulkhead
273-794	1/4" Plastic fittings, elbow
270-142	3/8" Amp fuse for 100/120 VAC
270-141	1/4" Amp fuse for 220/240 VAC

SECTION 6

PRINCIPLE OF OPERATION

The sensor is of the self-powered, diffusion limited, metal-air battery type as shown below. It contains an anode, electrolyte and an air cathode, to which the diffusion of oxygen is severely restricted by a diffusion barrier. At the air cathode, oxygen is reduced to hydroxyl ions which in turn oxidize the metal anode. The current is proportional to the rate of consumption of oxygen (Faraday's Law).

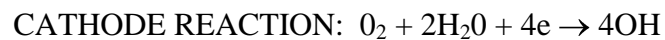
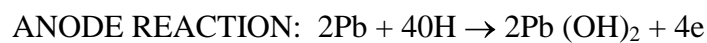
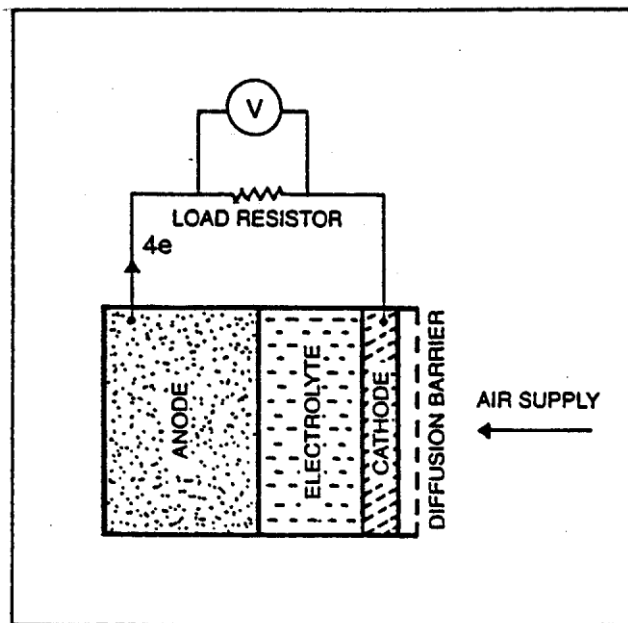

PRINCIPLE OF OPERATION (continued)

The sensor is operated in the limiting current region.

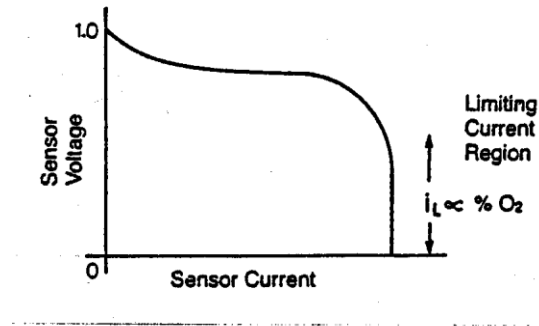

Here oxygen is consumed as fast as it reaches the electrode. The sensor voltage in this region is solely a function of the concentration of oxygen being sampled.

The unique capillary diffusion barrier offers higher performance and lower temperature and pressure coefficients than can be obtained with plastic membrane barriers.

SECTION 7

APPENDIX

7.1 PLASTIC FITTING INSTALLATION INSTRUCTION

1. Cut the tubing square and deburr it if necessary.
2. Place the compression nut over the tubing and insert the tubing into the fitting as far as it will go (approximately 1/2 inch).
3. Use a 5/8" open-end wrench to tighten the cap and retain the tubing. Rotate the fitting 3/4 turns. DO NOT over-tighten.

When reinstalling the tubing after it has been removed from the fitting, tighten the nut just until the fitting feels snug.

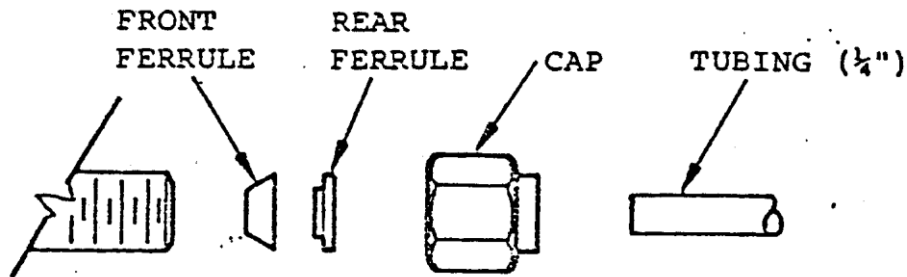

WARRANTY

Notice to Buyer and/or user of the analyzer:

Exclusion of warranties and limitation of damages and remedies

WARRANTY

This analyzer is warranted against defects in materials and workmanship under normal use and service for one year from the date of delivery to the original purchaser.

The sole obligation of the seller and/or manufacturer under this warranty is limited to repairing or replacing as the seller or manufacturer may elect, free of charge at the place of business of the seller or manufacturer, any parts that prove, in the seller or manufacturer's judgment, to be defective in materials or workmanship within one year after delivery to the original purchaser.

This warranty shall not apply and is void if, in the opinion of the seller and/or manufacturer, the portable analyzer or any component thereof has been damaged by accident, other causes not arising out of defects in materials or workmanship.

Before purchasing and using this analyzer, the user should determine the suitability of the product for his or her intended use and, the user assumes all risks and liabilities whatsoever in connection therewith.

If a product malfunction should occur, you may contact the seller or the manufacturer at:

Infrared Industries, Inc.

25590 Seaboard Lane

Hayward, Ca. 94545

Voice: 510-782-8100 or 800-344-0321

E-mail: service@infraredindustries.com

If it is necessary to return the analyzer, notify the seller in your area or Infrared Industries at the address above. Contact Infrared Industries for an RMA number, which is your authorization to send the unit. Note the RMA number on the outside of the box. Package the instrument carefully and securely. Do not ship the instrument with accessories. Please include a written description of any observation of the malfunction along with your name, address, and phone number. Then proceed to ship the instrument with freight prepaid to the address above.

WARRANTY EXCLUSIONS

THIS WARRANTY AND THE SELLER AND/OR MANUFACTURER'S OBLIGATION HEREUNDER IS IN LIEU OF ALL OTHER WARRANTIES, EXPRESSED OR IMPLIED, INCLUDING WITHOUT LIMITATION, THE WARRANTIES OF MERCHANTABILITY AND FITNESS FOR A PARTICULAR PURPOSE, AND ALL OTHER REPRESENTATIONS CONCERNING THE SALE, USE AND/OR PERFORMANCE OF THE ANALYZER.

No person is authorized to give any other warranties or to assume any other liability on behalf of the seller or manufacturer. This warranty shall not be extended, altered or varied except by written agreement signed by the seller and the buyer.

LIMITATION OF DAMAGES

IN NO EVENT SHALL THE MANUFACTURER OR SELLER OF THE PORTABLE ANALYZER BE LIABLE FOR ANY INCIDENTAL OR CONSEQUENTIAL DAMAGES ARISING OUT OF OR IN CONNECTION WITH ANY OBLIGATION IMPOSED UPON THE SELLER OR MANUFACTURER IN CONNECTION WITH THIS WARRANTY. SUCH INCIDENTAL AND CONSEQUENTIAL DAMAGES SHALL INCLUDE, WITHOUT LIMITATION, LOSS OF USE, LOSS OF INCOME, LOSS OF PROFIT (INCLUDING LOSSES TO BUSINESS INTERRUPTION), LOSSES SUSTAINED AS THE RESULT OF INJURY (INCLUDING DEATH) TO ANY PERSON, AND LOSS OF OR DAMAGE TO PROPERTY. THE LIABILITY OF THE SELLER AND/OR MANUFACTURER ON THIS WARRANTY IS LIMITED TO ACCEPTING RETURN OF THE PORTABLE ANALYZER, REFUNDING ANY AMOUNT PAID THEREON AND CANCELING ANY BALANCE STILL OWING ON THE EQUIPMENT. THIS REMEDY IS EXCLUSIVE-REPAIR OR REPLACEMENT PROCEDURE